

Product Description

The type PCB is a stainless steel single point load cell with complete hermetic sealing. It is a perfect fit for use in harsh industrial environments.

Application

- Bench and floor scales, packaging machines and conveyor scales

Key Features

- Wide range of capacities from 50 kg to 1 000 kg
- Stainless steel construction
- Environmental Protection IP68 with complete hermetic sealing
- Maximum platform size up to 1 000 x 1 000 mm
- High input resistance
- Integral mounting spacer

Options

- Y = 20 000 for C3 and C3 MI6
- Y = 25 000 for C3 and C3 MI6 (for 250 kg or higher capacities)

Approvals

- OIML approval to C3 and C3 MI6 (Y = 12 500)
- NTEP approval to 5 000 intervals, Class III
- ATEX hazardous area approval for Zone 0, 1, 2, 20, 21 and 22
- FM hazardous area approval

Packed Weight

Capacity (kg)	50	100	250	500	1 000
Weight (kg)	5.4	5.4	5.7	5.7	5.8

Available Accessories

- Compatible range of electronics

Specifications

		(E _{max})	kg	50 / 100 / 250 / 500 / 1 000		
Accuracy class according to OIML R60				(GP)	C3	C3 MI 6
Maximum number of verification intervals		(n _{LC})		n.a.	3 000	
Minimum load cell verification interval		(V _{min})		n.a.	E _{max} /12 500	
Temperature effect on minimum dead load output		(TC ₀)	%*RO/10°C	± 0.0400	± 0.0112	
Temperature effect on sensitivity		(TC _{RO})	%*RO/10°C	± 0.0200	± 0.0100	
Combined error			%*RO	± 0.0500	± 0.0200	± 0.0180
Non-linearity			%*RO	± 0.0400	± 0.0166	± 0.0166
Hysteresis			%*RO	± 0.0400	± 0.0166	± 0.0083
Creep error (30 minutes) / DR			%*RO	± 0.0600	± 0.0166	± 0.0083
Option	Min. load cell verification interval	(V _{min opt})		n.a.	E _{max} /20 000; 250 kg or higher: E _{max} /25 000	
	Temp. effect on min. dead load output	(TC _{0 opt})	%*RO/10°C	n.a.	± 0.0070; 250 kg or higher: ± 0.0056	
Rated Output		(RO)	mV/V	2 ± 5%		
Zero balance			%*RO	± 5		
Excitation voltage			V	5...15		
Input resistance		(R _{LC})	Ω	1 100 ± 50		
Output resistance		(R _{out})	Ω	960 ± 50		
Insulation resistance (100 V DC)			MΩ	≥ 5 000		
Safe load limit		(E _{lim})	%*E _{max}	200		
Ultimate load			%*E _{max}	300		
Safe side load			%*E _{max}	100		
Maximum platform size; loading acc. to OIML R76			mm	600 x 600 for 50 kg / 800 x 800 for 100 kg / 1 000 x 1 000 for 250...1 000 kg		
Maximum off centre distance at maximum capacity			mm	200 for 50 kg / 250 for 100...500 kg / 300 for 1 000 kg		
Compensated temperature range			°C	-10...+40		
Operating temperature range			°C	-40...+80 (ATEX -40...+60)		
Load cell material				stainless steel 17-4 PH (1.4548)		
Sealing				complete hermetic sealing; cable entry sealed by glass to metal header		
Protection according EN 60 529				IP68 (up to 2 m water depth) / IP69K		

The limits for Non-Linearity, Hysteresis, and TC_{RO} are typical values.
The sum of Non-linearity, Hysteresis and TC_{RO} meets the requirements according to OIML R60 with $\rho_{LC}=0.7$.

Dimensions (in mm)

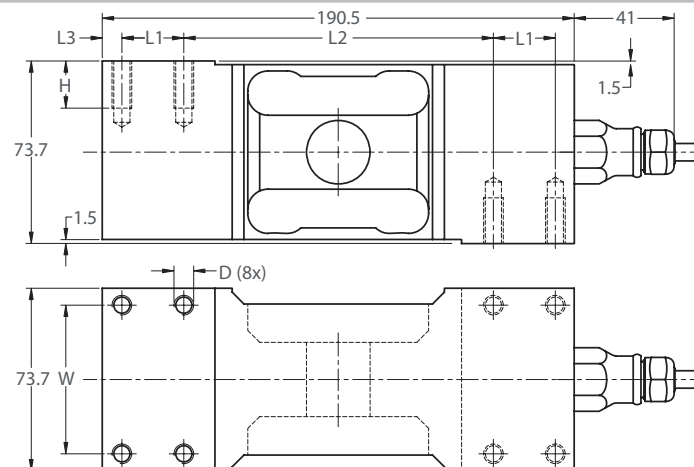

Type	L1	L2	L3	H	W	D	Mounting bolts	Torque ¹⁾
PCB-50/100/250/500/1 000 kg	25	125	8	19	60	M8 2)	M8 8.8 / PCB-1 000 kg: M8 12.9	25 Nm
PCBB-500/1 000 kg	35	104,5	8	25	57	M12	M12 8.8	90 Nm
PCBC-50/100/250/500/1 000 kg	35	107	6.75	19	50	M8 2) 3)	M8 8.8	25 Nm

1) Torque values assume oiled thread. 2) Unified thread 5/16-18 is available. 3) OIML approval only valid for M8 threads.

Wiring

- The load cell is provided with a shielded, 6 conductor cable (AWG 26) or with a shielded, 4 conductor cable (AWG 24). Cable jacket polyurethane.
- Cable length: 3 m
- Cable diameter: 5 mm
- The shield is floating or connected to the load cell body

